

Woven Fabric Rewinding Machine

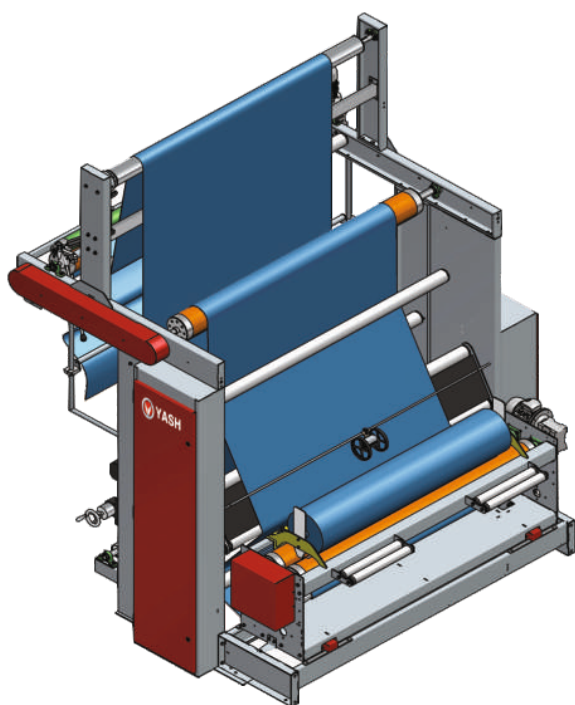

Model - RP

The Woven Fabric Rewinding Machines **RP** are our advanced range of fabric rolling, measuring and cutting machines used for various types of grey and finish stable woven fabrics. These machines are designed for fabric manufacturers, garment factories, fabric distributors and warehouses. With single or multiple input and output options, these are versatile machines that can be customized to meet specific customer needs.



Features & Options

- PLC controlled synchronizing system
- Full forward & reverse run
- End detector
- Electronic counter meter
- Selvedge guider for straight rolling
- Selvedge shifting device for thick selvedge
- Paper tube rack
- Variable roll compactness
- Face In Face Out winding
- Cross cutter
- Automatic weighing
- Multi-functional Controller
- Roll Handling, Packing & Sorting

Application



WOVEN



NON WOVEN



TECHNICAL
TEXTILES



KNITS



HOME
TEXTILE



CARPET

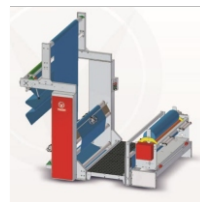

Specifications

Working Width	1800 - 3800 mm
Input	Pile / Roll / Big Batch
Output	Roll / Big Batch

Roll Diameter	300 - 1500 mm
Machine Speed	5 - 80 mtrs. / min
Power Supply	415V AC - 50 / 60 Hz.